

# WORKSHEET: MARI MIGDAL-AYN'S ALABASTER EGG USING CENTRAL LAYOOESH PILLAR AND ASCENDING BENU BIRD.

THEORY: THE "EGG" IS THE MERKABA FIELD OF THE RESHEL FEMALE HALF. IT CHANGES SIZE AND SHAPE TO ENCLOSE THE MANY DIFFERENT RESHEL REALITY FRAMES. (NOTE CHELEM, CHELEMUTH, CHELEMESH IN HEBREW: EGG, DREAM, STONE, FIRE, DEATH.)

L-GATE, CORNER STONE, GOLDEN RATIO RHOMBUSES

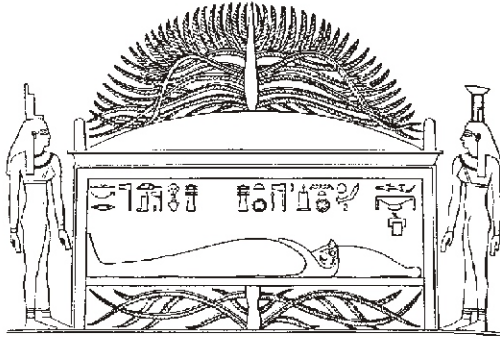
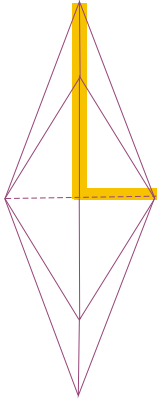

HATHOR TEMPLE (DENDERA) ISIS/NEPHTHYS AND HERU-UR IN A DIONE-COUPLET FORMAT; RESHEL, L-GATES, 36 POLE AND POWER RING FORMING THE PENTAGON FOR RESHEL AND THE PHOENIX / BENU ASCENSION.

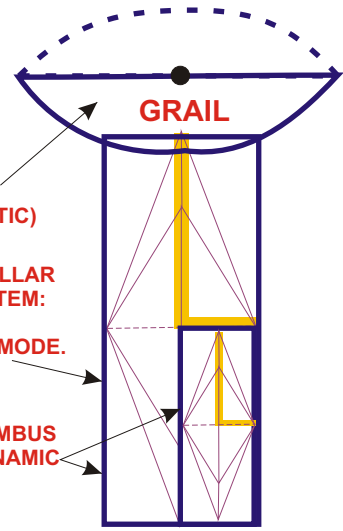

LETTER AYIN (PROTOSINIATIC)

THE TOWER-PILLAR RHOMBIC SYSTEM: A GATE AND A MANIFESTING MODE.

DOUBLE RHOMBUS OR "YUD" DYNAMIC

HYPOTHETICAL PILLAR-TOWER OF NEPHTHYS OR MIGDAL-AYIN

36 POLE, (10 DEGREES) BASED ON THE L-CUT AS THE SACRED CHORD. CREATES AN INNER HOLOS RING. SACRED CHORD BETWEEN THROAT CHAKRAS.

PHOENIX RISING (RED WITH GREEN WINGS UP); CHAMBER OF THE SON ANGLE IN THE BODY.

SPECIAL OR-A'HIM RING LINKING CENTER OF ISIS/NEPHTHYS L'S WITH THE BASIC GLORY POLE (PYR. APEX) AND THE TETRAHEDRON APEX. (THE VERTICAL POSTS MARK THE TETRAS' BASE POINTS.) THIS PROVIDES A FLOWER OF LIFE STAR TETRA WITHIN THE BASIC PYRAMID!

ISIS THRONE

THIS BASE LINE IS THE EVENT HORIZON FOR THE HEART CHAKRA SUBSYSTEM.

GRAIL "CUP"

PYRAMID BASE: THE THRESHOLD OF SYTHIA

"ALABASTER EGG" HAS VARIABLE DIMENSIONS

GOLDEN RATIO VAULT, EXPANDED BY ISIS' AND NEPHTHYS' CROWNS.

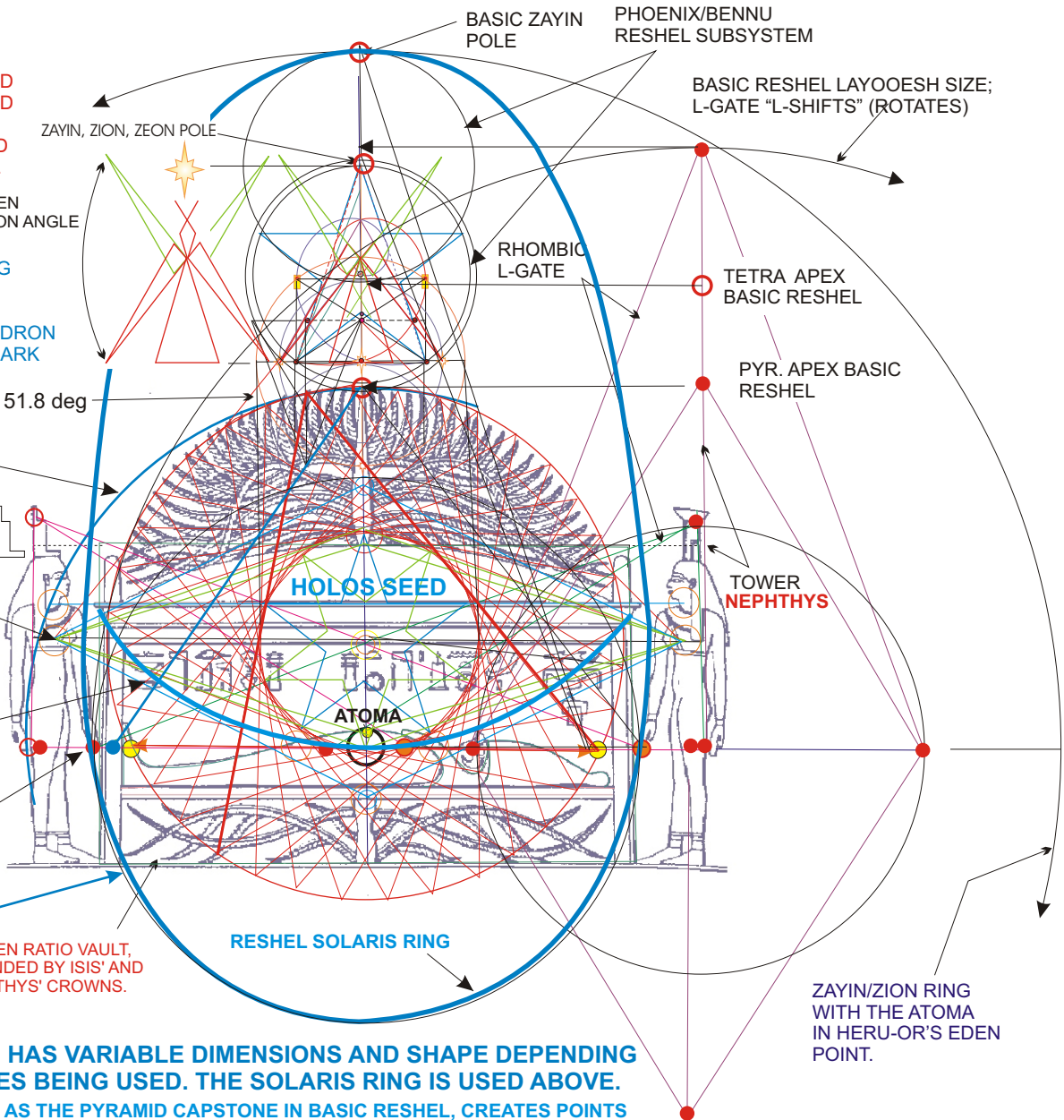

HOLOS SEED

ATOMA

RESHEL SOLARIS RING

ZAYIN/ZION RING WITH THE ATOMA IN HERU-OR'S EDEN POINT.

MARI MIGDAL-AYN'S EGG HAS VARIABLE DIMENSIONS AND SHAPE DEPENDING ON THE RESHEL'S CIRCLES BEING USED. THE SOLARIS RING IS USED ABOVE. (BENU RESHEL MATRIX SHOWN AS THE PYRAMID CAPSTONE IN BASIC RESHEL, CREATES POINTS OVER THE PYRAMID'S APEX.)