

RESHEL SYSTEM BASE ON HORIZON OF THOTH RESONANT WITH THE PRIMARY RESHEL IN THE CLOUD.

SACRED CHORD THROUGH THE FINGER TIPS/THIGH GENERATES 36 POLES; AT CROWN LEVEL MATCHES CHORD WITH ANOTHER 36 (=72).

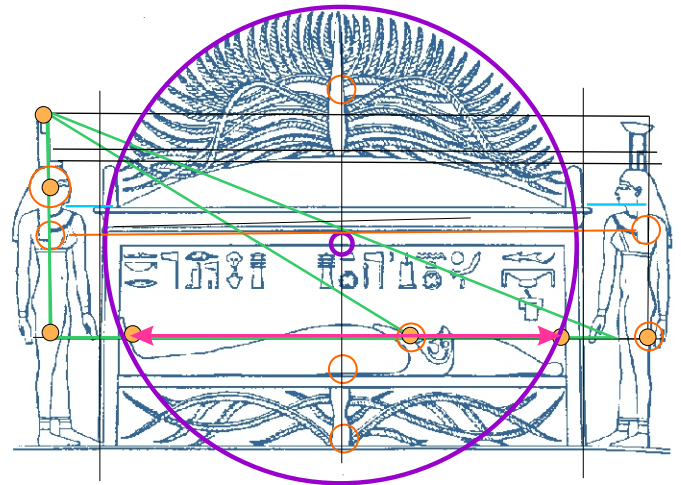
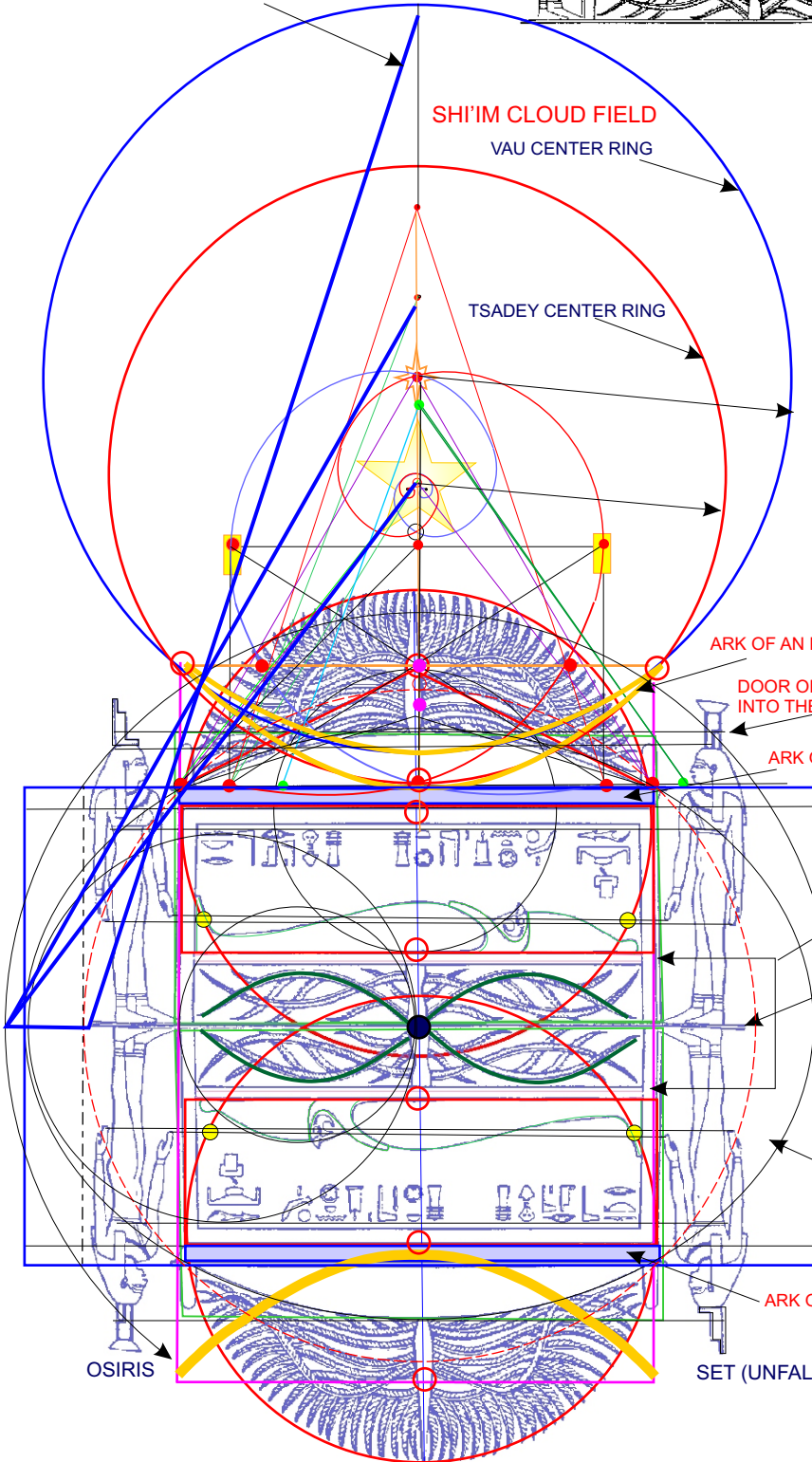

THE ARK RATIO MEASUREMENT IN SCRIPTURE (2.5 X 1.5 X 1.5) IS USED BUT WITH A SELAH FIELD BAND IN THE CENTER.

THE "MALE" ARK OF EBEN IS A MIRROR IMAGE OF THE ARK OF AN (GRACE) BUT WOULD PROBABLY HAVE TWO MALES (OSIRIS AND SET) AS THE COUPLET. (THEORY AT PRESENT).

THE TSADEY RING CLOSELY FOLLOWS THE PARABOLIC RING OF THE MAIN CUP CURVE. THESE TWO STATES MERGE IN THE GRAIL CUPS' MAIN TEYTH AND DALLET POLES ON THE CUP'S RIM CONDITIONING THE NATURE OF THE TELEPLANE SURFACE OF THE ELIXIR.

THE CENTRAL SELAH FIELD SHOWS ROOTS THAT CONDUCT LIFE FLOW INTO THE TREES.

THE HUMANS ARE FEET-TO-FEET ON THE HORIZON OF THOTH. THEY THEN PROJECT TO FORM THE TWO BASIC ARK ELEMENTS.

THERE ARE TWO HORUS-UR FIGURES THAT ARE ALSO FOUND IN THE DENDEIRA CEILING PLAN. THEY WOULD REPRESENT BOTH THE SON AND DAUGHTER.

THE "MALE" ARK OF EBEN'S U'RIAH CLOUD IS NOT SHOWN FOR CONVENIENCE.

CUBE'S SPIN SPHERE

CHORHII GAP IN THE EDEN TREE ENCLOSES THE CUBE WITHIN THE ARK AND ITS COVERS. WE OBSERVE THAT THE OVOIDS' MAJOR AXIS IS ENCLOSED WITHIN THE LENGTH OF THE ARK'S 2.5 MEASUREMENT (RELATIVE TO THE 1.5 CUBE MEASUREMENT). THIS WOULD BE SAYING THAT THE CHORHII FIELD ENCLOSES THE CUBE BUT HAS A PORTION OF THE ARK WITHIN THE PHENOMENAL DYNAMIC FLASHING UNIVERSE (?).

HATHOR TEMPLE (DENDEIRA) HERU-UR ARK CONSTRUCTION:  
DIONE COUPLET AND RESHEL, L-GATE DYNAMIC.  
ISIS AND NEPHTHYS POLARITY AND ASSOCIATED GEOMETRY